

Operating instructions

- Intended use.** This Power Tool is intended for industrial applications, for cutting sheet metal (maximum capacity is indicated in the Specifications), for use with cutting jaws and cutting blades which are indicated in these operating instructions or recommended by DRÄCO.
- Do NOT cut sheet metal along welding points. Do NOT cut multi layer sheets, which exceed the maximum cutting capacity.
- Switching ON/OFF the power tool.** First check cable and plug for damage. Slide the switch pad (5) **BACKWARD** for switching **ON** the power tool. Slide the switch pad (5) **FORWARD** for switching **OFF** the power tool.

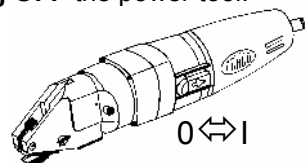

- For inside cutting, the shortest curve possible has a radius of 45 mm ($\pm 1\frac{3}{4}$). If cutting a radius with the right hand, cut from right to left. The outside radius is unlimited.

- For **cutting out** curved or circular inside patterns, a 14 mm ($\pm 1/2$ ") hole, or a punched slot should be made to insert the centre cutter.
- If after cutting, a **small strip** remains this can easily be trimmed off to the exact measurement, without leaving a burr or any distortion of the material. Just one side of the power tools can be used for cutting also (e.g. along a marked line). Lift the power tools out of the shavings while the motor is running. Cut off longer shavings.
- Both knife and jaws can be sharpened. After being sharpened or replaced, the knife at its lowest point should protrude the jaws by approximately 3 mm. The knife should have approximately 0,05 mm (0,005") play on each side of the jaws, centring the cutter with spacing shims supplied.
- Every 200 operating ours have the cutting blade and cutting jaws sharpened at a specialist workshop.
- Ensure that the material to be cut is free of oil and grease.**

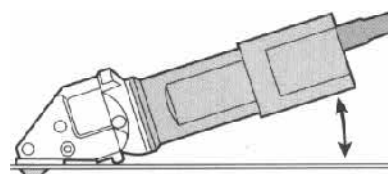

Care and Maintenance



Before working on machine disconnect from power supply by removing plug from socket. Always keep the machine and the ventilation slots clean. Oil the knife pin and knife at regular intervals. If the machine should happen to fail despite the care taken in manufacture and testing, repair should be carried out by an authorised customer services agent for DRÄCO power tools

Environmental protection



Recycling raw materials instead of waste disposal

Machine, accessories and packaging should be sorted for environment-friendly recycling. These instructions are printed on recycling paper manufactured without chlorine

Warranty

DRÄCO tools carry a guarantee of 12 months from date of delivery. Damage attributable to normal wear and tear, overload or improper handling will be excluded from the guarantee. (e.g. blades/knives and jaws) In case of complaint please send the machine, **undismantled**, to your dealer or the DRÄCO Service Center for electric power tools.

CE-Declaration of conformity

We declare under our sole responsibility that this product is in conformity with the following standards. EG 98/37 EG, EG 73/ 23 EG, EG 89/336 EG, or standardisation documents EN 292 part I, EN 292 part II, EN 50 144, EN 55 014, EN 60 555, HD 400, HD 400.3 part II/H

CE 95 Max Draenert



Operating Instructions for the Radius-Seam Metal Shear 3514-7R

To avoid any disturbance please read the following instructions:

For your safety:



1 Safe operation of this machine is possible only when the operating instructions and the safety precautions are read completely and the instructions contained therein are strictly observed.

2 The machine must not be used in a wet environment.

3 Always inspect cable and plug before using machine. Only have damage repaired by a qualified professional. Put the plug into the mains socket only when the machine is switched off.

4+5 Always wears protective goggles, protective gloves and heavy-duty shoes when working.

- Do not carry the machine by the cable.
- Always remove the plug from the power supply socket before carrying out any work on the machine, when interrupting work and when not using the machine.
- Always place the cable to the rear away from the machine.
- Apply the machine to the sheet metal only when switched on.
- Always provide for secure footing when working.
- Firmly clamp the work piece if it dose not remain stationary from its own weight.
- The knife should not rub on the jaws: Possible danger of cutting tool breakage.
- Do not exceed the maximum allowable material thickness especially when cutting over double folded joints or welded seams.

For further notes on safety refer to enclosed sheet

DRÄCO Radius Seam Metal Shear	type	3514-7R
max. cutting capacity	Art.no.	61080
steel	400 N/mm ²	mm/ga. 2,0 / 14
stainless steel	600 N/mm ²	mm/ga. 1,5 / 16
stainless steel	800 N/mm ²	mm/ga. 1,3 / 18
aluminium	250 N/mm ²	mm/ga. 3,0 / 10
duct- & Pittsburgh Seam	400 N/mm ²	mm/ga. 4 x 0,90 / 21
tightest radius	mm/ "	45 / 1 3/4
working speed ±	m/min	5-7
strokes	min ⁻¹	2400
motor capacity	Watts	500
weight	kg	2
starting hole	Ø mm	14

3514-7R	
spare parts	
knife	37140
set of jaws	BG37222
knife-pin set	BG35055
optional accessories	
metal-box	18000

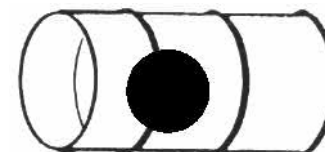

spiral ducting

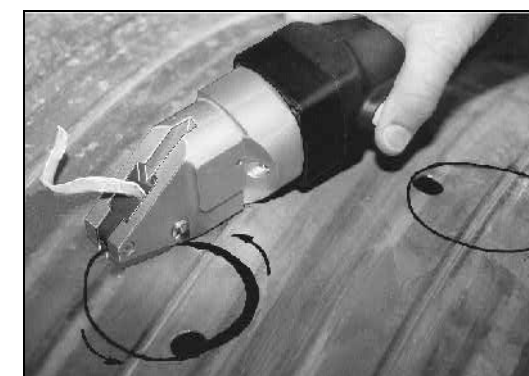

starting hole 12-14 mm Ø
accurate cutting along a marked line

Spare part List DRÄCO Radius Seam Metal Shear 3514-7R

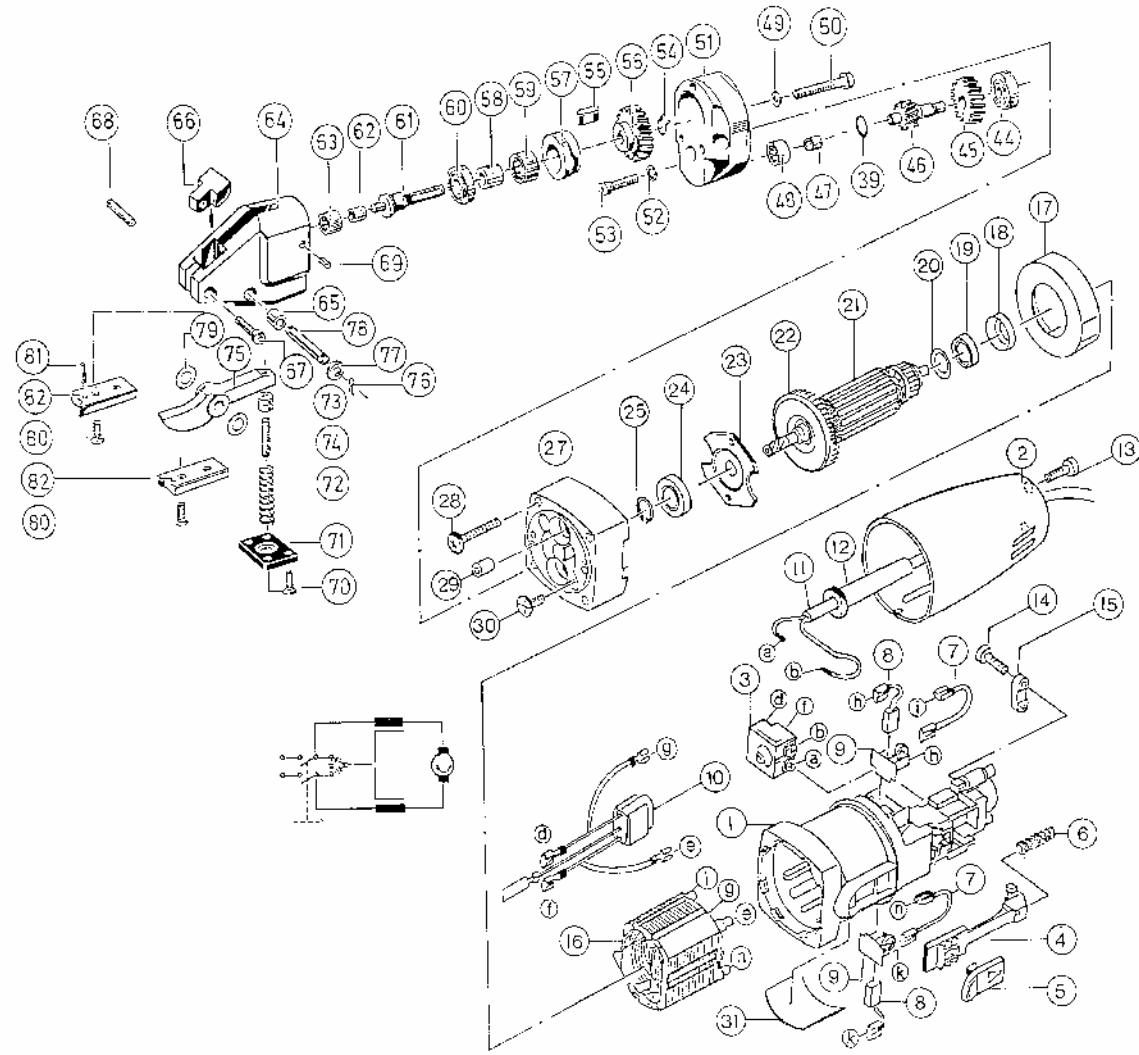

Replacing/Adjusting the Knife

Before working on machine disconnect from power supply by removing plug from socket. Wear protective glasses!

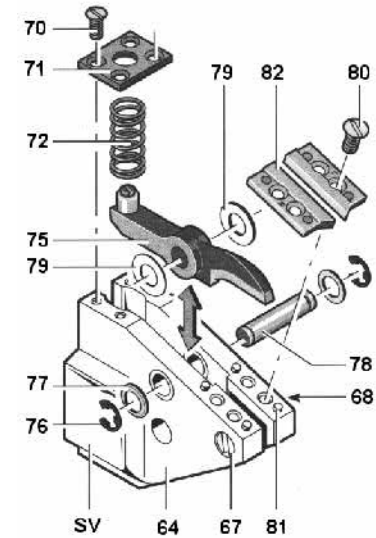

Replacing the Knife

Clamp the machine in a vice on the clamping surfaces SV between aluminium protective jaws.

Unscrew the screws 70 and remove the spring plate 71. Remove the spring 72. Remove the Cotter Pin 76 and the Washer 77. Push back the knife pin 78.



Do NOT interchange the Spacing Shims 79: the wrong spacing could ruin the jaws and knife. Insert a new knife with the old spacing Shims 79. Insert the knife pin 8. Mount the washer 77 and the Cotter Pin 76. Insert the spring 72. Reassemble spring plate 71.

Replacing the Jaws

Loosen the screws 80 and remove the jaws 82. Press out the positioning pins 81. Mount new jaws and positioning pins. Tighten the screws 80.

Adjusting the knife Clearance

For clearance between knife and jaws that is too large, loosen the fillister head screw 67. Adjust the clearance with the setscrew 68. Retighten the fillister head screw 67.



The knife must not rub on the jaws: Danger of breakage. Note: If heavy burring is produced while cutting, repeat the adjustment.

Sharpening the Knife/Jaws

The Knife and the Jaws must be sharpened and adjusted at the same time. This work should be performed by an authorised DRÄCO customer service location. Send in the complete machine for this purpose.

Pos.	Description	Qty.	Order-No.	Pos.	Description	Qty.	Order-No.
	Shear Head 3514-7R cpl. assembl. Pos. 35, 39, 44-82	1	37515	39	Washer	3	81059
				44	Ball Bearing	1	13039
				45	Gear	1	13540
				46	Pinion	1	13041
	Drive Shaft cpl. Pos. 54-62	1	BG31558	47	Sleeve	1	13042
	Pinion with Gear cpl. Pos. 39, 44-47	1	BG31541	48	Needle Bearing	1	13043
	Motor cpl. 230 V	1	32229	49	Securing Washer	3	81249
	Motor cpl. 115 V	1	32129	50	Screw	3	81262
1	Motor Housing	1	32040	51	Gear Case Cover Pos. 48-53	1	BG13046
2	Housing Cap	1	32047	52	Securing Washer	2	81243
3	Switch	1	32050	53	Hex Socket Screw	2	81031
4	Guide Piece	1	32054	54	Circlip	1	10009
5	Switch Pad	1	32056	55	Key	1	10006
6	Pressure Spring	1	32055	56	Gear	1	13051
7	Wire	2	32044	57	Cover for Needle Bearing Pos. 57+59	1	BG10450
8	Carbon Brush	2	32042	58+62	Sleeve	1	10005
9	Carbon Brush Holder	2	32041	59+63	Needle Bearing	1	10300
10	Condensator	1	32045	60	Roller Bearing	1	35285
11	Cable with Plug	1	32046	61	Eccentric Shaft assembled Pos. 54+55,60-62	1	BG35556
12	Connection Cable	1	32522	64	Head Casting Pos. 63-65+69	1	BG37547
13	Screw	2	32048	65	Knife Pin Bushing	2	35542
14	Screw	2	32053	66	Spacing Block Pos. 66-68	1	BG37059
15	Cable Collar	1	32052	67	Screw	1	81176
16	Field 230 V	1	32039	68	Tap Screw	1	81120
16	Field 115 V	1	32139	69	Tap Screw	2	81239
17	Air Deflector Ring	1	32038	70	Screw	4	81285
18	Rubber Sleeve	1	32036	71	Spring Cover Plate	1	12300
19	Ball Bearing	1	32030	71	Spring Cover Plate Pos. 70-72	1	BG12300
20	Washer	1	32037	72	Spring	1	12200
21	Armature 230 V	1	32033	73/74	Knife Adjust Screw with Locking	1	35566
21	Armature 115 V	1	32133	75	Knife 3514-7R Pos. 73-75	1	37140
23	Bearing Cover	1	32032	78+79	Knife-pin set BG12400+BG35145	1	BG35055
24	Ball Bearing	1	10038	76	Safety Cotter Pin	2	35054
25	Securing Ring	1	32034	77	Washer	2	81072
27	Bearing End Plate	1	32014	78	Knife Pin Pos. 76-78	1	BG35145
28	Screw	4	32010	79	Spacing Shims Set	1	BG12400
29	Pin	1	81132	80	Screw	4	81286
30	Screw	2	32012	81	Pin	4	81248
31	Rating Plate	1	32057	82	Set of Jaws 3514-7R	1	37222
				82	Set of Jaws 3514-7R Pos. 80-82	1	BG37222

Max Draenert GmbH & Co.KG Electric - Cordless - Pneumatic Tools - Machines Germany

Werk I: Administration
Production Shears
K-Series
Internet: <http://www.dracotools.com>

D-73777 Deizisau
D-73779 Deizisau

P.O.Box 1120
Gutenbergstreet 15-17
Tel. +49-7153-8217-0
Fax +49-7153-8217-66

E-mail: draenert@dracotools.com