

... the Roof- and Wall Program of

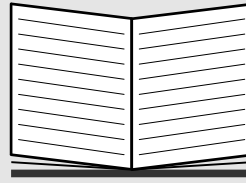

# Instruction Manual



Please read this manual, before attempting to operate this machine and observe all safety regulations and signs.

## Automatic Power Seamer

### K9-1

(for Double Lock Standing Seam)

### K9-1-WAD

(Complete version, for Single- and Double Lock Standing Seam, Dual-Safety Switch & Seam Cutting)

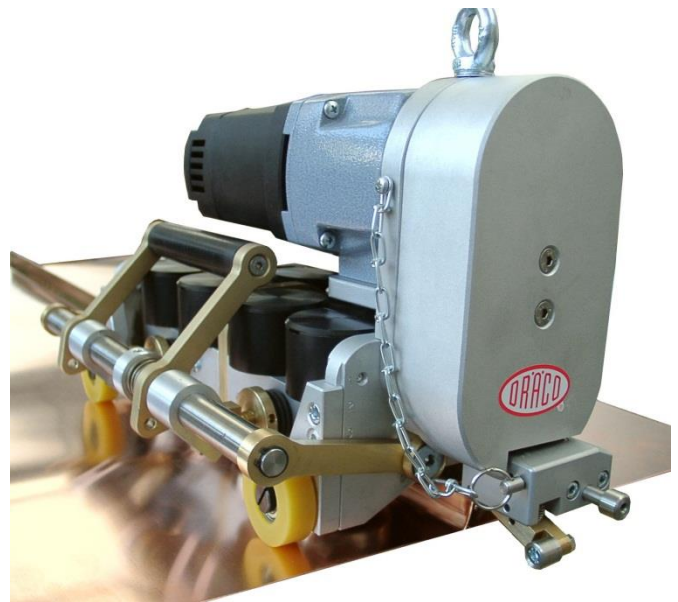

Pic. K9-1-WAD



Mach.-No.:

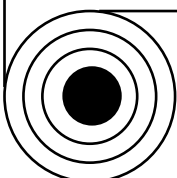
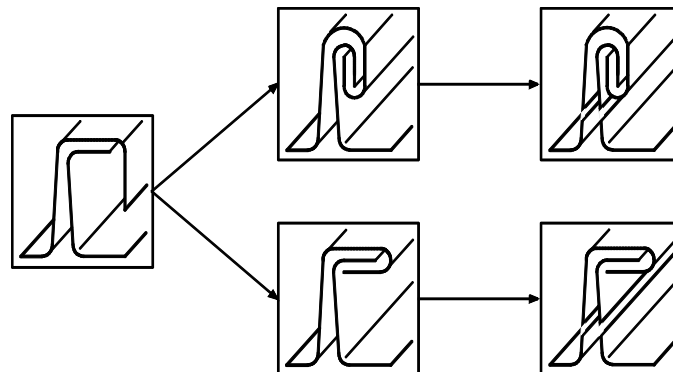

**Max Draenert Apparatebau GmbH & Co.KG – Electric – Cordless – Pneumatic Tools – Machines**

Factory 1

D-73777 Deizisau

P.O. Box 1120

Phone +49-(0)7153-8217-0

Gutenbergstr. 15-17

D-73779 Deizisau

Fax +49-(0)7153-8217-66

INTERNET <http://www.dracotools.com>

E-Mail: [draenert@dracotools.com](mailto:draenert@dracotools.com)

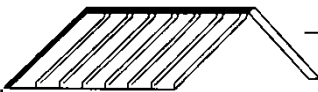

# Index

Page

|   |           |
|---|-----------|
| <b>GENERAL INFORMATION</b>                              | <b>2</b>  |
| PICTOGRAM EXPLANATION                                   | 2         |
| USERS REFERENCE   | 2         |
| USERS OBLIGATION  | 2         |
| <b>SAFETY INDICATION</b>                                | <b>3</b>  |
| <b>TECHNICAL DATA</b>                                   | <b>4</b>  |
| <b>FUNCTION</b>   | <b>5</b>  |
| <b>CONTENT</b>  | <b>5</b>  |
| NORMAL EQUIPMENT  | 5         |
| ACCESSORIES   | 5         |
| REMOTE CONTROL K9-1-KF                                  | 5         |
| <b>OPERATION INSTRUCTIONS</b>                           | <b>6</b>  |
| ENVIRONMENT CONDITIONS                                  | 6         |
| CHECKUP BEFORE OPERATING                                | 6         |
| <b>WORKING WITH THE POWER SEAMER (DOUBLE LOCK SEAM)</b> | <b>7</b>  |
| PREPARING THE PANELS                                    | 7         |
| PREPARING SEAM TO INSERT THE SEAMER                     | 7         |
| PREPARING THE POWER SEAMER                              | 7         |
| VARIABLE PRESSURE ADJUSTMENT                            | 7         |
| <b>WORKING CONSEQUENCE CLOSING THE SEAM</b>             | <b>8</b>  |
| <b>WORKING WITH ACCESSORIES</b>                         | <b>9</b>  |
| CHANGING ROLLS FOR STANDING SEAM                        | 9         |
| CUTTING ROLLS K9-1-AR                                   | 10        |
| CLOSING LOCK HANDLE                                     | 11        |
| <b>CHANGING FORMING STATIONS K9-1</b>                   | <b>12</b> |
| STAINLESS STEEL SEAMING                                 | 12        |
| CLOSING BARREL CURVED PANELS                            | 12        |
| <b>CUTTING ROLLS K9-1-AR</b>                            | <b>13</b> |
| SPARE PARTS LIST CUTTING ROLLS K9-1-AR                  | 14        |
| 5 STEPS TO RECYCLE OR REPAIR A PANEL                    | 15        |
| <b>WINTERSET K9-1-WS</b>                                | <b>16</b> |
| ASSEMBLING  | 16        |
| <b>DUAL SAFETY SWITCH K9-1-DF</b>                       | <b>17</b> |
| FUNCTION  |           |
| CHECK UP DUAL SAFETY SWITCH DF                          | 17        |
| WORKING INSTRUCTIONS DF                                 | 18        |
| <b>WORKING WITH THE REMOTE CONTROL K9-1-KF</b>          | <b>18</b> |
| <b>VARIABLE PRESSURE ADJUSTMENT K9-1-ASS</b>            | <b>19</b> |
| <b>CONTROL BOX</b>                                      | <b>20</b> |
| <b>SHORT DESCRIPTION START UP K9-1</b>                  | <b>21</b> |
| <b>WORKING ADVISE WITH SAFETY SWITCH</b>                | <b>22</b> |
| <b>MAINTENANCE ADVICE</b>                               | <b>23</b> |
| <b>WARRANTY</b>   | <b>24</b> |

|                           |          |
|---------------------------|----------|
| SAFETY PRECAUTIONS        | attached |
| DECLARATION OF CONFORMITY | attached |

## GENERAL INFORMATION

Please read the safety regulations carefully. These should always be followed to reduce the risk of personal injury. Read these instructions before attempting to operate this product, it will help to reduce any accidents.

### PICTOGRAM EXPLANATIONS

In the operation manual all safety regulations are mentioned with following Pictograms:

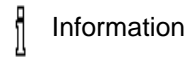

Information

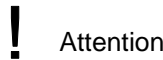

Attention



Danger general



Danger specific



Signs Outdoors



Prohibition Signs

### USERS REFERENCE

Power Seamer K9-1, K9-1-WAD, can be used to close or to cut open seams only, please see technical data and read the manual how to operate the seamer.

### USERS OBLIGATION

All Operators must educate themselves as to the proper operation and uses of this equipment. The Operation Manual must be kept with the machine at all times.



## Safety Indicators for Users and Operators



When working at the wall or roof, ensure that everything conforms to the local health and safety regulations.

Before plugging in and using Seamer check plug and cable also accessories if damaged.



Consider work area environment in rain or snow, working on Metal Roofs is prohibited after DIN18339.

Any damage on Seamer, send machine in to the manufacturer for servicing.



DANGER / ACCIDENT



Check label for voltage, the electric mains connection must correspondent.



Don't expose the Seamer to rain or snow, the Power Seamer can be used in damp locations on account of water-protection resistance after IP 54



The Seamer must be operated on a grounded socket only, to guard against an electric shock. Danger due to electric shock.



Guard against electrical shock.



Disconnect plug from socket, before machine - adjustment or servicing and when not in use. Injury – Danger.



Do not transport Seamer or Metal Box with a lifting crane.



Operate Seamer only when located on top of the panel. Injury.



Working overhead with the seamer is not allowed.



Ensure that the forming stations are positioned correctly, (numbers). Use Original Forming Rolls only.



The Seamer must work freely without force, do not push or pull and do not sit or stand on top of the machine. Danger, accident.



Before profiling check the rolls, for right position, that they are located in the pin and the screws tight.



The Operator must secure himself when working with the machine. Danger Accident.



Lifting eyes are provided to enable a safety rope or cable to be fitted, especially when working on vertical claddings or on a steep slope on top of the roof.

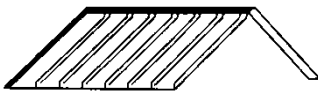

## Technical Data

### K9-1 Basic Version

| Parameter                                  | Figures     | Standard          |
|--|-------------|-------------------|
| <b>Machine Type</b>                        | <b>K9-1</b> |                   |
| <b>K9-1 Stations (Forming sets)</b>        | <b>4</b>    |                   |
| <b>Motor data</b>                          |             |                   |
| Voltage single phase                       | 230 or 115  | V~                |
| Power                                      | 1150        | W                 |
| Amps                                       | 6,3         | A                 |
| Protection dampness                        | ●           | IP54              |
| Weight without accessories                 | 22          | kg                |
| Speed, variable                            | 5,5 - 13    | m/min             |
| Fuse                                       | 6,3         | A (slow)          |
| <b>Metal Thicknes (Roll-form qualität)</b> |             |                   |
| Aluminium, Zinc, Copper                    | 0,8 / 20    | mm / gauge        |
|  | 280         | N/mm <sup>2</sup> |
| Steel                                      | 0,7 / 21    | mm / gauge        |
|  | 370         | N/mm <sup>2</sup> |
| Stainless Steel                            | 0,5 / 24    | mm / gauge        |
|  | 400         | N/mm <sup>2</sup> |
| Min. Radius                                | 2 or 1,2    | m                 |
| Seam Height                                | 25 - 60     | mm                |
| Panel width min.                           | 140         | mm                |
| Recommended Material temperature min.      | + 10 / +40  | °C / °F           |

Technical changes can be made without prior notice 06/22.

### Technical Data Accessories

Technical Data of Winterset K9-1-WS see manual blower page 16.

### Panel Configuration Control Measurements

- |   |                            |   |                          |
|---|----------------------------|---|--------------------------|
| A | Min. width of panel 140 mm | D | Up to 15 mm              |
| B | from 24 mm                 | E | Measurement D - (5 x s)* |
| C | from 25 mm                 | F | Measurement D - (5 x s)* |

\* s = Material Thickness

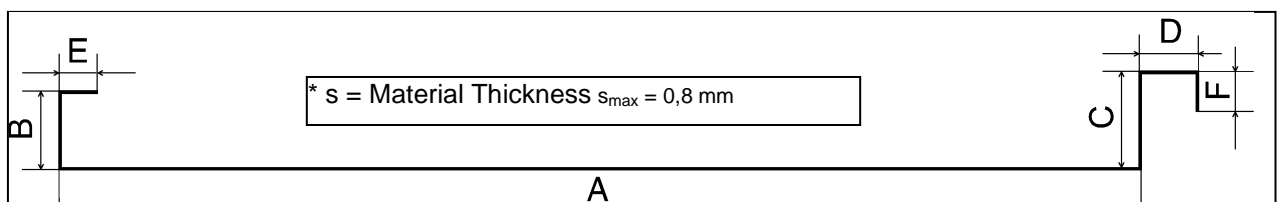



## FUNCTION

Power Seamer K9-1-WAD is a new combination of DRÄCO patented functions all together, to close a single-, or double lock seam, cutting rolls K9-1-AR set, to cut the seam open for renovation or repair at the roof or wall.

Seamer K9-1 or K9-1-WAD is a light weighted machine at an advanced working speed between 5,5 - 13 meter per minute. A seam at the wall 90 degrees up or down can be handled without a problem. All materials can be closed to a seam in a clean transition, also at cross seams.

The high seam quality is achieved through 8 drive rolls. Two rubber drive rolls work, without leaving scratch marks on painted or coated sheets, up to 0,8 mm, and stainless steel 0,6 mm in thickness.

Four outrigger wheels can be adjusted for different seam heights from 25 to 60 mm. The variable pressure adjustment K9-1-ASS can be adjusted to achieve an optimum closed seam.

To close barrel curved roofs, a radius of 2 meter is possible without any adjustment. A brass-washer under forming stations No. 1 and No. 1.4 minimizes the radius to 1,2 meter. Clean transition at the clips and cross seams due to the spring washers and the variable pressure adjustment K9-1-ASS.

Seamer K9-1 version closes the profiled panels to a double lock seam. Multifunctional accessories are: single lock forming rolls K9-1-WR, dual safety switch K9-1-DF, set of cutting rolls K9-1-AR, winter set K9-1-WS, remote control K9-1-KF.

For recycling or repairing a panel at the roof or wall, the cutting rolls K9-1-AR can be mounted to the seamer to cut open the single or double lock seam.

Lifting eyes are assembled to the seamer to enable a safety rope or cable to be fitted, especially when working on vertical claddings or on a steep slope on top of the roof. Overhead working with the seamer is not allowed.

Safety first on site, roof or wall is our endeavor, the patented dual safety switch K9-1-DF prevents the seamer to fall off the roof, stops automatically at the end of a seam, gutter or ridge, wall or obstructions.

Winter Set K9-1-WS, attached to the seamer and speed control in low working speed, (under + 10°C) for trouble free seaming in cold temperatures. Ideal for best results in seaming.

## CONTENTS

Please check package for completeness.

### BASIC EQUIPMENT:

- 1 Power Seamer K9- 1, for double lock seam
- 1 Manual
- 1 Transport box
- 1 Allen Key
- 2 Spare Screws

### Assembled:

- Variable Speed Control
- Variable Pressure Adjustment System K9-1-ASS
- Socket for Dual –Safety Switch K9-1-DF
- Socket for Remote Control K9-1-KF with FORWARD-STOP-REVERSE-Function

### Accessories for K9-1

(Not included in Basic equipment)

- Set Forming Rolls Single Seam K9-1-WR
- Set Of Cutting Rolls K9-1-AR
- Dual Safety Switch K9-1-DF
- Remote Control K9-1-KF
- Winter Set K9-1-WS
- Hand Seamer K8 Single Lock
- Hand Seamer K7 Double Lock

### Remote Control Information (option)

The remote control for forward and reverse operation

is ideal to close the single lock seam at the facade or wall from the ground, comfortable.



### Attention

A double lock seam can only be closed in forward operation. Reverse operation of seamer a knot will be between the single and double lock seam. To avoid the knot, open the locking handle move seamer about 30 cm backwards until the seamer is stationed above the double lock seam, close the locking handle again and switch to reverse operation. Always safeguard the machine.

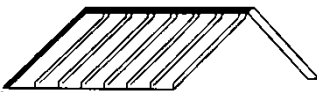

# Operating Instructions

Starting up Seamer K9-1(-WAD)

When working on site, please follow the safety regulations in your country, read these instructions before attempting to operate this machine.

## Environment Conditions

Working on top of the roof by rain and snow is not allowed. Safety regulations and accident prevention DIN 18339.

**Danger of accident**

The Power Seamer K9-1(-WAD) can be used in damp locations due to water protection resistance after IP 54. Do not use in heavy rain or snow.

**Guard against electric shock!**

When working on vertical claddings, on a steep slope at the end of the roof, secure a safety rope to the lifting eyes to prevent machine falling off the roof.  
**Accident prevention.**

## Check before operating the seamer

Before plugging the machine into the electricity supply check plug and cable also all accessories if damaged. Any damage observed, please send machine in to the manufacturer for servicing.

Check label for voltage, the electric mains connection must correspondent.

The seamer must be operated on a grounded socket or extension cable only, to guard against an electric shock.  
**DANGER**

Before servicing or adjusting the Seamer unplug cable from socket.  
**INJURY**

■ Take Seamer K9-1(-WAD) out of the metal case, lay machine level with the forming stations to the ground.

■ Check Seamer, accessories, plug and cable for damage once more.

! Any damage observed send machine in for servicing.

! Noticeable examination outside.

### Height adjustment

■ Check outrigger wheels for correct height adjustment and screws tight.

### Forming rolls

■ Rubber and forming rolls must be free of grease and oil. Check forming station numbers for correct alignment.

! **Function check**  
! Switch must be positioned to "0" switch light off.

! Always work with the 4 outrigger wheels at the side of the seamer

■ Operate seamer only on grounded connections, socket, extension cable or cable drum.

■ Switch machine to "1", switch lights up, press Start Button.

All 8 forming rolls must turn.

! When a dual safety switch (K9-1-DF) is assembled to the seamer, lift bottom feeler up, put pin into hole no. 1 to lock feeler.

### ATTENTION

Position no. **1 non operation**  
Position no. **2 in operation.**

■ Switch machine off  
■ Wait until all forming rolls come to a stand still  
Unplug cable

**If there is no notice of defects, the Power Seamer is ready to work according the regulations.**

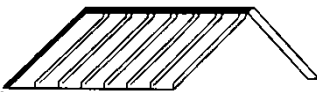

## WORKING WITH the POWER SEAMER Double Lock Seam



Before working with the power seamer K9-1(-WAD), please read chapter operation instructions page 6.  
**Read the safety indications and pay attention to.**

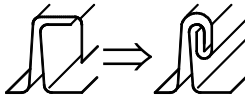

### Preparing the panels

- Fit the clips to the first panel.
- The next panel overcloak, over the undercloak

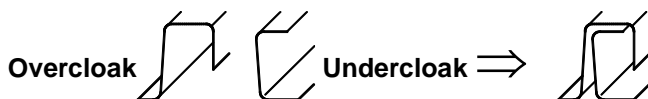

### Preparing seam to insert the seamer

Before inserting the K9-1(-WAD), to close the seam and if not possible from the outside, close panel with hand seamer K8 two times and one time with hand seamer K7.

To avoid seamer to work itself out of the seam, close long panels every 2 to 3 meter with the hand seamer K8.

### Variable Pressure Adjustment

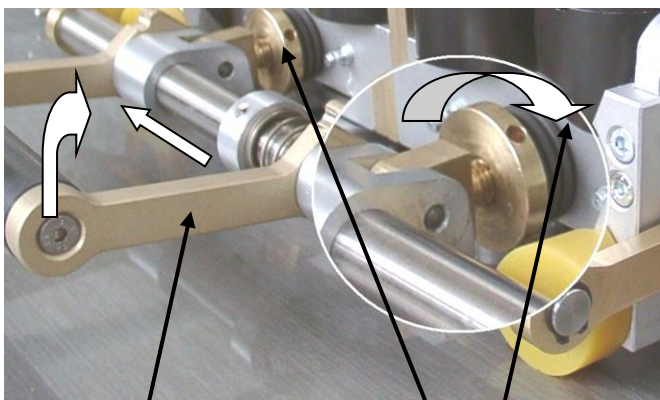

Moveable locking handle, folds up

Ring for pressure adjustment

## PREPARING THE SEAMER

### Adjustment of outrigger wheels

The outrigger wheels can be adjusted to 3 different heights.

- Number 1: 25 - 38 mm
- Number 2: 38 - 50 mm
- Number 3: 50 - 60 mm

The outrigger wheels stabilize the seamer when working on top of the roof or at the wall. All 4 wheels must be adjusted to the same height and there should be clearance between the roll and the material.

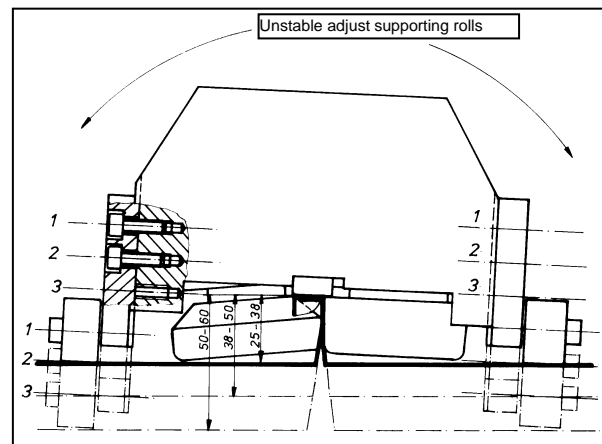

Height adjustment of out rigger wheels No. 1, 2, or 3

Fasten screws after adjustment



The outrigger wheels with the brackets are marked with R (right) and L (left) and must always be assembled to the marked side of the machine.

### Attention!:

**Before changing the pressure setting, the pressure must first be released from the rollers using the locking handle (loosen, locking handle up).**

To achieve an optimum closed seam, adjustment might be necessary for hard materials. (Trial run check, sample)

### Adjustment of pressure

**Increase pressure:** Turn both adjustment rings regular clockwise to increase the pressure.

**Decrease pressure:** Turn both adjustment rings anti – clockwise to decrease the pressure.

The pressure can be changed on both rings; (see arrows) A sample panel should be closed to check the seam.

**Adjustment pressure rings should be turned anti clockwise to "0" after non-operation, to relieve the disk springs.**

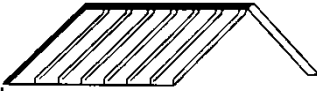

### WORKING CONSEQUENCE CLOSING THE SEAM

! Dual safety switch K9-1-DF assembled to the seamer, check the position of pin first before switching the seamer to "on".

**If pin is in position 1 the machine will not switch off automatically!**

Pin in position 2 the dual safety switch is in operation.

! Before working with the dual safety switch, check the function of the switch.

⚙ Working direction variable up or down.

- Insert the seamer, locking handle open, with the four forming rolls into the panel.
- The first two forming rolls No. 1 and No. 2 must be set under the single lock seam. See picture.

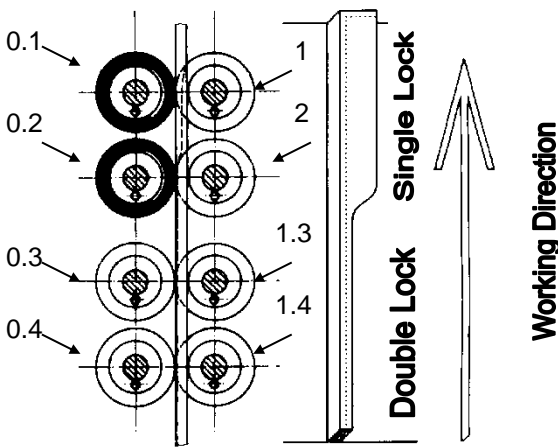

Insert the rolls no. 1 and no. 2 at the beginning of the seam

! The locking handle must be positioned to the forming side

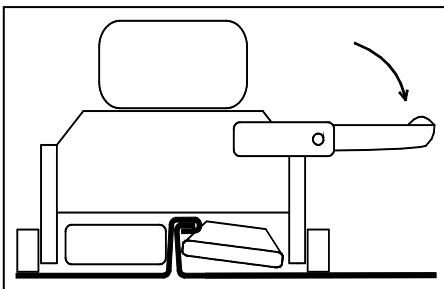

Lock handle

! Press locking handle down all the way, to ensure that the handle does not open up again.

! Secure a safety rope to the lifting eyes.

- Seamer must be operated on a grounded socket only.
- To operate seamer switch to "I" and push knob 2 (see page 20)
- After switching the machine to on position the power seamer will work automatically and close the panel to a double lock seam.
- At the end of the ridge or eave switch machine to "0" off.
- Open locking handle.
- Take seamer out of the panel.

If there is an obstruction, the rest of the panel has to be closed with the single lock hand seamer K8 and double lock seamer K7.

If there is an obstruction, windows, chimneys, vent pipes, move locking handle against the spring and to the top. See picture previous page.

Take seamer out of the panel, move locking handle down, spring pushes pin into the bracket, move handle to the top and take seamer off.



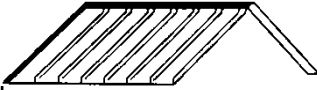

## WORKING WITH ACCESSORIES

Changing forming stations K9-1-WR for single lock seam.

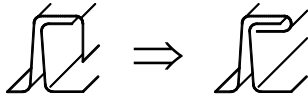

Before working with the power seamer K9-1(-WAD) make sure you read the operation instructions as well as safety indications.

Read all of the safety regulations and instructions carefully.



Disconnect plug from socket before machine adjustment, servicing and also when not in use. Injury - Danger.

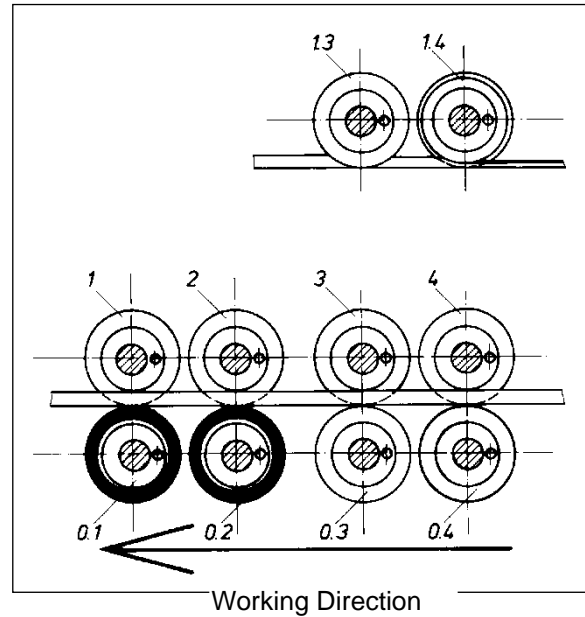

Sequence of assembling forming stations

- Loosen the allen screws, double lock forming stations 1.3 and 1.4.
- Take both rolls off the shaft.
- Assemble single lock forming rolls 3 and 4 to the marked numbers at the side of the seamer 3 and 4, turn the rolls until the pin settles itself into the hole of the shaft.
- Changing to double lock seam again, follow instructions reverse as mentioned above.
- Preparing the panels and the seamer read chapter working with the Seamer.

i

Lay out panels one after one, fasten clips, close the panel with the Seamer, or single lock hand seamer K8, to achieve a clean single or double lock seam.

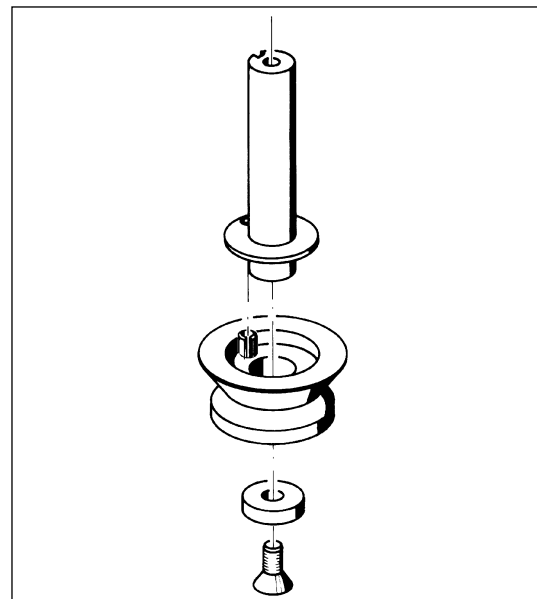

Assembling forming stations to the shaft

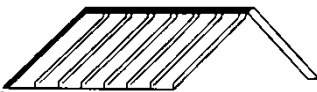

## Cutting Rolls K9-1-AR



Please read the operation instructions as well as safety indications before working with the power seamer K9-1(-WAD).

Read all the safety regulations and instructions carefully. All instructions have to be followed.

### Changing seamer for seam cutting

Loosen the screws on the following forming stations. See chart.

|             | Rolls to be used |   |     |     |
|-------------|------------------|---|-----|-----|
| Double lock | 1                | 2 | 1.3 | 1.4 |
| Single lock | 1                | 2 | 3   | 4   |

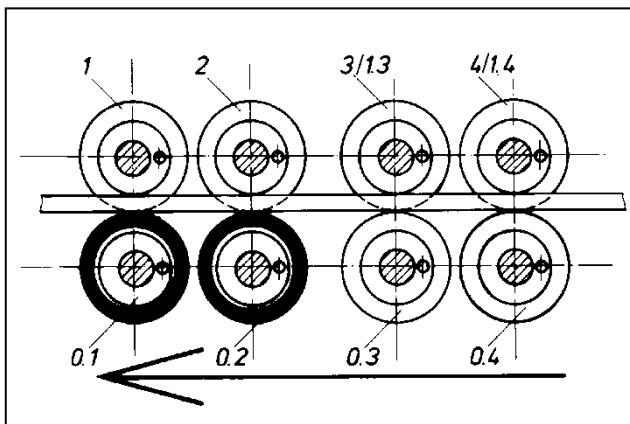

Forming stations diagram

- Take the rolls position 3/1.3, 4/1.4 and 0.3 0.4 off the shaft
- Assemble cutting rolls 3 and 0.3 to the marked numbers at the side of the seamer 3 and 0.3.
- Turn both rolls until the pin settles itself into the hole of the shaft.
- Fasten cutting rolls with screws again.

To prevent waste jam in the seamer, no forming stations to station 1.4 or 0.4. The machine works only with 4 driving rolls and 2 cutting rolls.

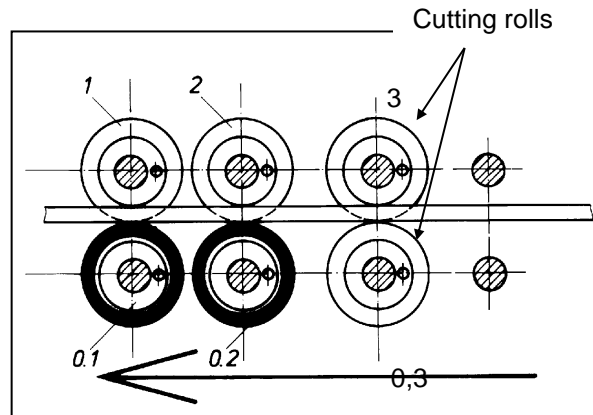

Changing to double or single lock, follow instructions reverse as mentioned above. See chart.

- Working Sequence Cutting Double Lock- or Single Lock Seam



Seam cutting, a burr could be on both sides of the panel.

### Injury - Wear gloves

Working direction variable up or down or opposite.

Open locking handle all the way.

Set seamer, with the first two rubber drive wheels into the panel.

Cutting rolls must be stationed just before cutting the seam if there is an obstruction, cut seam about 20 cm by hand set machine in and switch machine to "on"

**!** The locking handle must be set to the side of the seam.

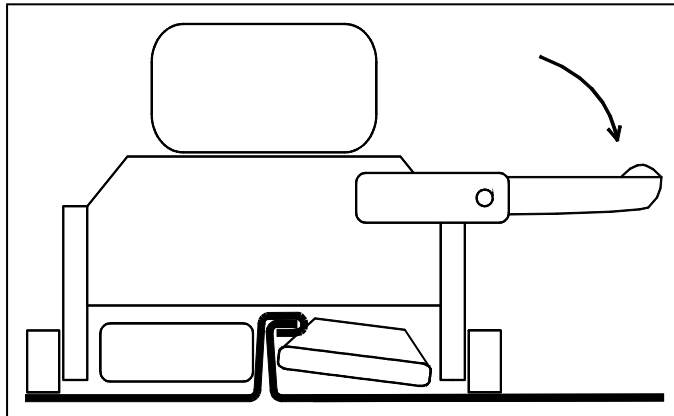

Locking handle closed

- Close locking handle until engaged.
- Closed locking handle must be parallel to the panel.
- ! ■ If handle is not closed correctly, when working, it could open back up.
- ! ■ For safety reason, always fasten rope to lifting eyes.
- Operate seamer on grounded connections, extension cables or cable drums, only.
- Switch machine to "on" and press "start" button.

The seamer cuts the seam open automatically.

- At the end of the seam, switch machine off, or set back switch no. 6 to stop. See page 20.
- Open locking handle.
- Take seamer out of panel.

If the seamer runs against an obstruction, the rest of the seam has to be cut open by hand.

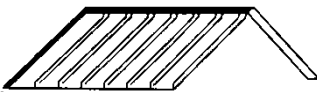

## Change of Forming Stations K9-1(-WAD)

### Forming station assembly on shaft

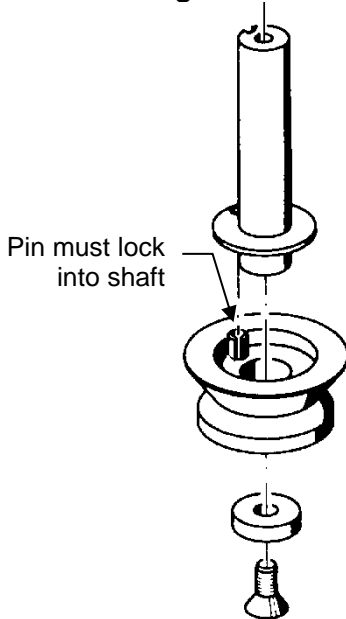

### Standing Seam Forming Stations (Option)

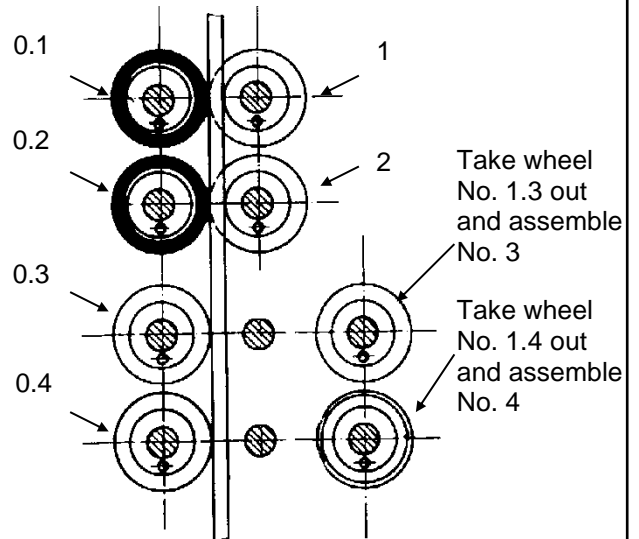

### Double Seam Forming Stations (standard)

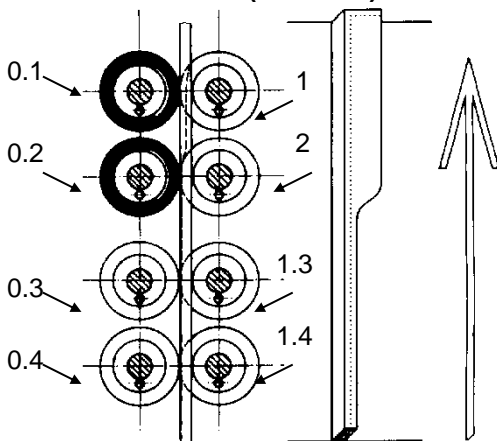

### Cutting Rolls (option)

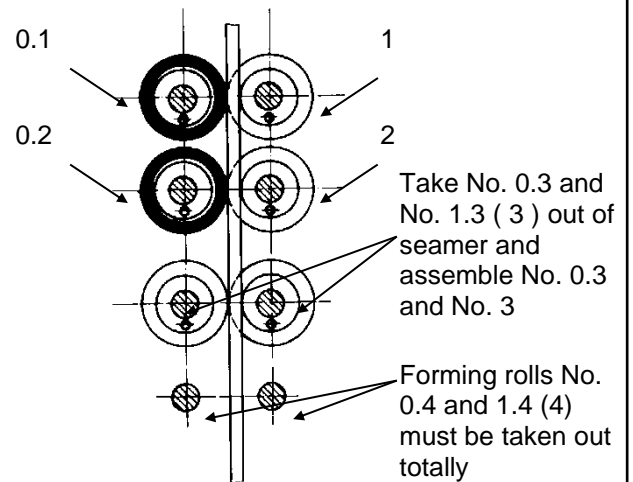

### Closing Stainless Steel Panels

To close a single-or-double lock seam in stainless steel panels, for example Uginox, to achieve an optimum closed seam, pressure adjustment rings have to be turned for high-pressure materials. See page 7: **pressure adjustment**.

We recommend, when using seamer on site, check seam-closure on a sample panel first.

### Barrel Curved Roofs

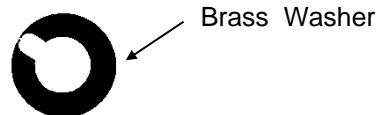

For closing barrel curved roofs under the dimension of 1,5 m radius insert one washer each under forming station No. 1 and No. 1.4 (forming roll No. 4 Standing Seam). Due to the washers, it is possible to close barrel curved roofs down to a radius of 1,2 m.



## Cutting Rolls K9-1- AR Changing of cutting blades

### Sequence of operation:

Changing cutting blades station 3 and 0.3.  
To change cutting blades loosen 4 screws (pos. 10) to take cutting blades off. If there are no chips and not too blunt, they can be resharpened.

### Assembling:

The resharpened or new cutting blades, insert into cutting blade holders 3 and 0.3 and tighten these with 4 screws.  
Please make sure, that numbers 3 and 0.3 match the cutting blades and cutting blade holders.

### Cutting roll station 3

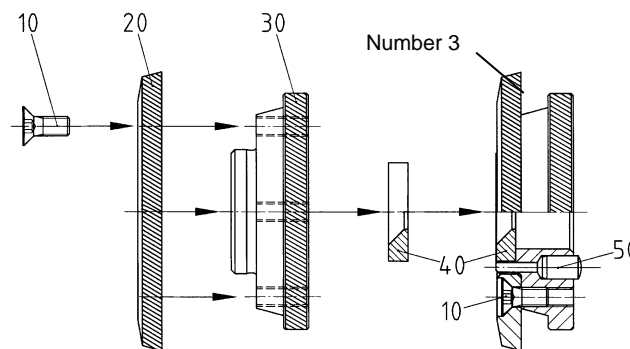

### Cutting roll station 0.3

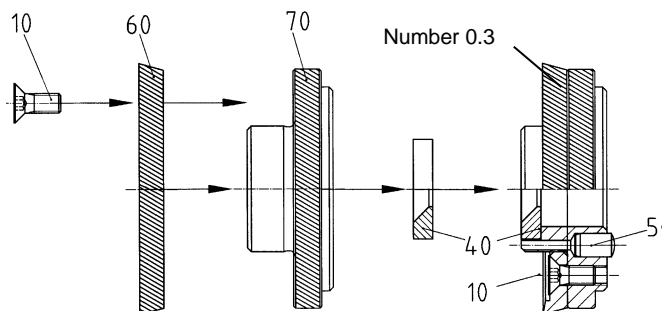

| Pos. | Order no. | Item                             | Pieces |
|------|-----------|----------------------------------|--------|
| 10   | 81238     | Screw M5x12                      | 8      |
| 20   | K 906303  | Cutting blade station 3          | 1      |
| 30   | K 906301  | Cutting blade holder station 3   | 1      |
| 40   | K 906280  | Brass insert                     | 2      |
| 50   | 81265     | Pin Ø 6x12                       | 2      |
| 60   | K 906304  | Cutting blade station 0.3        | 1      |
| 70   | K 906300  | Cutting blade holder station 0.3 | 1      |
|      | K 900080  | Mounting Screw M6x12             | 1      |

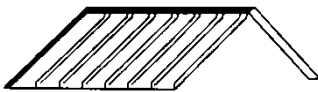

### Spare Parts List for cutting rolls K9-1-AR Set order No. BG91625-1

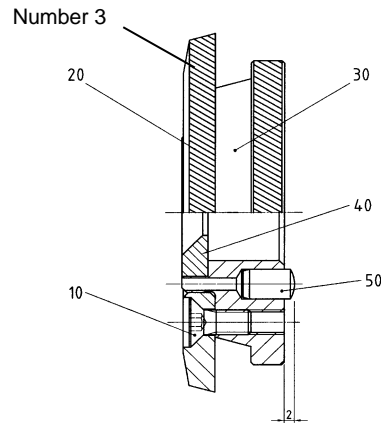

| Pos. | Order no. | Item                            | Pieces |
|------|-----------|---------------------------------|--------|
|      | BG900299  | Cutting roll station 3 complete | 1      |
| 10   | 81238     | Screw M5x12                     | 4      |
| 20   | K 906303  | Cutting blade station 3         | 1      |
| 30   | K 906301  | Cutting blade holder station 3  | 1      |
| 40   | K 906280  | Brass insert                    | 1      |
| 50   | 81265     | Pin Ø 6x12                      | 1      |

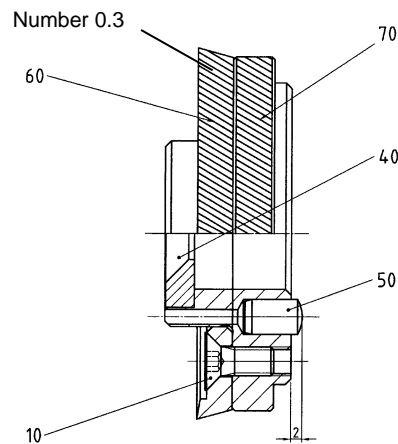

| Pos. | Order no. | Item                              | Pieces |
|------|-----------|-----------------------------------|--------|
|      | BG900300  | Cutting roll station 0.3 complete | 1      |
| 10   | 81238     | Screw M5x12                       | 4      |
| 40   | K 906280  | Brass insert                      | 1      |
| 50   | 81265     | Pin Ø 6x12                        | 1      |
| 60   | K 906304  | Cutting blade station 0.3         | 1      |
| 70   | K 906300  | Cutting blade holder station 0.3  | 1      |

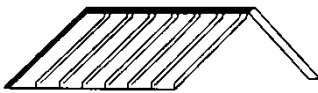

**For recycling or repairing one panel in standing or double lock seam, using cutting rolls K9-1-AR step 1-5**

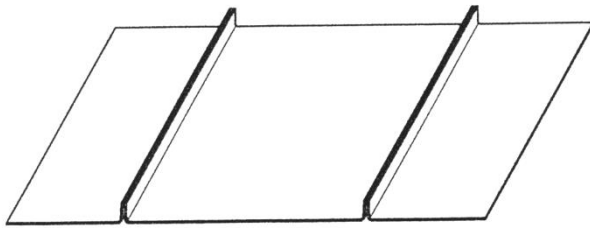

- 1.) Cutting of two seams leaving an upstand of 8 mm

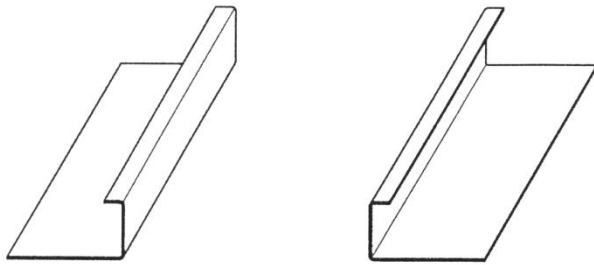

- 2.) Bend both sides up 24 mm, with a hand bending tool.

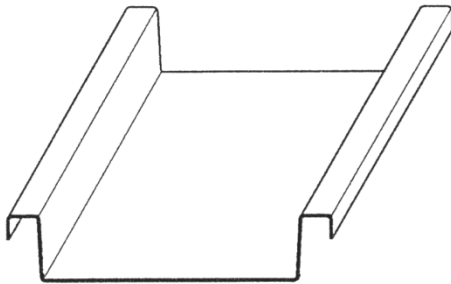

- 3.) Form a wider panel both sides overcloak, U-U profil.

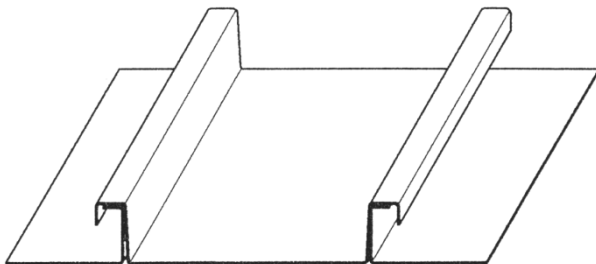

- 4.) Fasten cleats, lay wider panel over undercloak

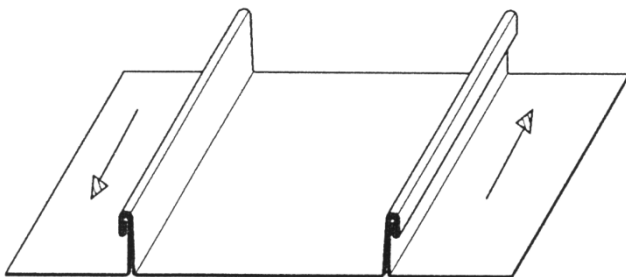

- 5.) Close to a single or double seam with hand seamers K8 and K7 or with power seamer K9-1(-WAD) working direction up and down.

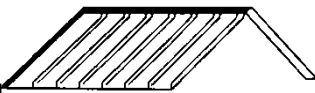

## Winterset K9-1-WS (option)



Before switching hot air blower on, read the instruction sheet about the winter set.



Disconnect plug from the socket if any maintenance is necessary to the seamer or blower.



The hot air blower can heat up to 650° C, 1202 ° F  
**DANGER OF FIRE!**  
Keep away from inflammable articles.



Seam and hot air blower, as well as reflector can get very hot.  
Do not touch.  
Danger of burns.



**Wear safety gloves at all times!**



Optional accessory, winter set K9-1 WS is used when outside temperatures are low. The hot air blower will warm up the seam to achieve an optional closed seam.

**!** If a temperature of +10°C on top of the seam is not reached, turn the electronic speed control to a lower working speed, minimum 5,5 m/min.

### Assembling Winter Set to Seamer K9-1 (-WAD)

Disassemble eye screw (1)

Blower bracket (2) assemble with eye screw (1) and tighten.

Tighten worm screw (3)

Push reflector (6) from the bottom towards the blower and tighten screw.

Feed hot air blower (4) from the top into the bracket (2) and tighten 3 screws (5) equal, finger tight.

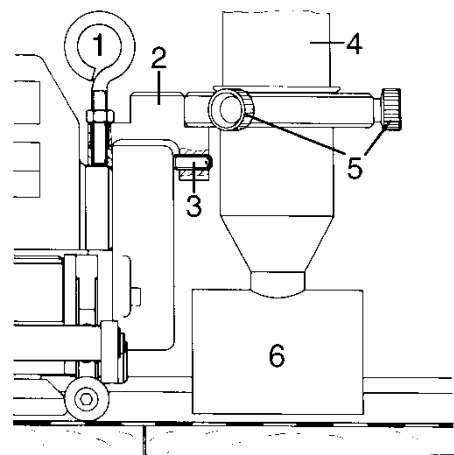

The hot air blower winter set can be electronic regulated up to + 650° C, 1202 ° F.

**i** For technical data, Winter Set K9-1-WS see instruction sheet hot air blower.



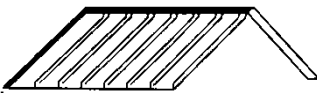

## DUAL-Safety Switch K9-1-DF (option)

Safety first on site is our endeavour.

The patented Dual Safety Switch K9-1-DF is constructed for safety, to stop the seamer automatically at the ridge, eave or any other obstructions on top of the roof or wall.

- ! When working on vertical claddings, on a steep slope or at the end of a roof, secure a safety rope to the lifting eyes in front or backside of the seamer to prevent machine falling off the roof, even if the dual safety switch is assembled.
- ! Power Seamer K9-1 without a dual safety switch K9-1-DF the item can be fitted in the factory, afterwards.

### Function

At the end of the ridge, eave or any other obstructions the machine shuts off automatically due two switches at the front and below the seamer.

Check dual safety switch before working with the machine:

- Seam switch below, push to top.
- Insert pin in hole no.1
- Switch machine to "on" (pin in hole no.1) all forming stations must turn.

Press front switch, seamer shuts "off", all rolls come to a standstill.

- Seamer can be activated, switch machine off and to on again. All forming station must turn.
- Take pin out of hole no. 1, and insert pin in hole 2.

Seamer power shuts off. All rolls come to a standstill.

- Switch machine off to "0".

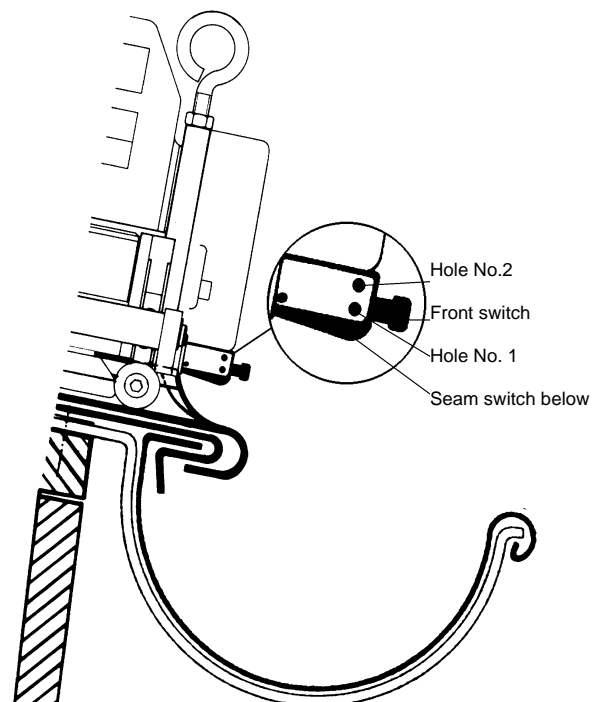
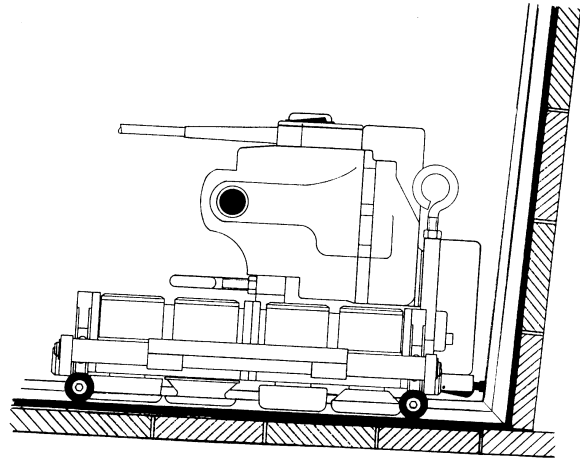

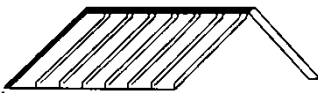

## WORKING SEQUENCE - DUAL SAFETY SWITCH K9-1-DF

To activate the dual safety switch:

- Take pin out of hole no. 1.
- Insert pin in hole no. 2.
- Set seamer on top of the seam.

**!** Attention: The bottom seam switch must be placed on top of the seam.

- Switch machine to "ON", push START Button.

The seamer K9-1(-WAD), will close the seam to a single or double lock automatically.

Automatically the seamer stops at the end of the panel.

- Switch to "0" STOP.
- Open locking handle.
- Take machine out of seam.

At the end or beginning close the remaining seam, with the single lock hand seamer K8 or to a double lock hand seamer K7.

### To set the seam switch out of order:

- Take pin out of hole 2.
- Push seam switch to the top.
- Insert pin in hole 1, to lock the seam switch, the dual safety switch is out of order.

**!** *Attention: Check dual safety switch every time before working with the seamer. Check the setting of the pin no.1 or 2.*

### WORKING WITH THE REMOTE CONTROL K9-1-KF

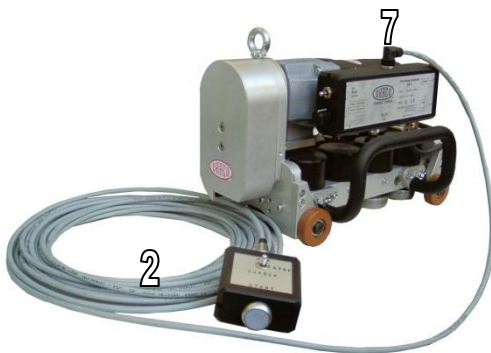

Seamer K9-1  
with remote control K9-KF and cable

Using remote control, take off temporary plug (7, without cable) first. Insert remote control cable into plug and tighten. The control center shuts off the function of the seamer, when the remote control cable is engaged. The variable speed control knob no.5 is still in function and can be used for high and low speed.

Reverse operation the dead man's handle will be automatically activated, the start button must be held for operation permanently, because of safety reasons.

**After removing remote control cable (2), insert temporary plug (7) again, otherwise the seamer is out of function.**

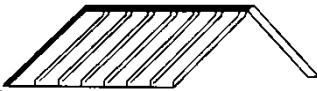

# POWER SEAMER K 9-1 Variable pressure adjustment K9-1-ASS



## Service Tip: Pressure Adjustment

Depending on the hardness of the materials, the pressure to the forming stations has to be increased to achieve an optimum closed seam.

Pressure can be changed on both adjustment rings regular.

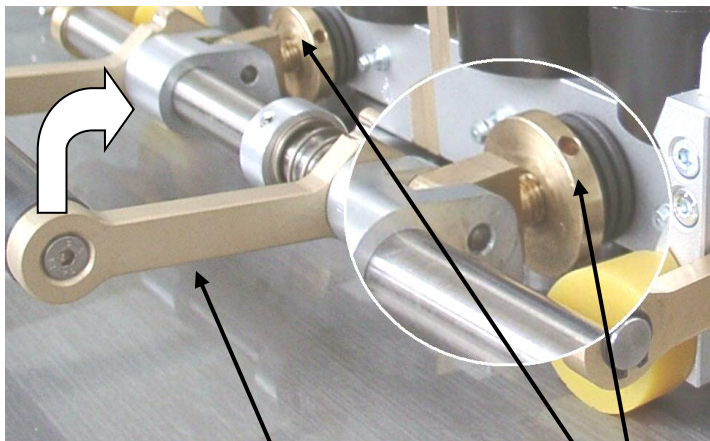

**Increase pressure:** Turn both adjustment rings clockwise

**Decrease pressure:** Turn both adjustment rings anti-clockwise

After the adjustments are made, check seam closure on a sample panel.

Seamer in non-operation, turn both rings anti-clockwise to reduce pressure to the disk springs.

Loosen locking handle before adjusting the pressure

Adjustment rings with pin hole

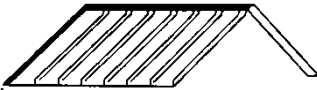

# ELECTRONIC SWITCH BOX



1. Main switch on – off
2. Start pushbutton
3. Socket for Dual Safety Switch K9-1-DF
4. Fuse
5. Variable speed knob
6. Switch for forward-stop-reverse
7. Socket for remote control K9-1 KF (+ temporary plug)

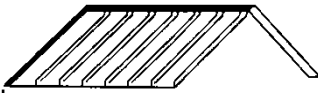

## **Instructions how to start up the Power Seamer K9-1**

1. Check voltage, power supply and label on power seamer for correspondence.
2. Plug seamer K9-1 into power outlet.
3. Push red switch to on (No. 1). Light burns.
4. Choose with switch (No. 6) forward , reverse or stop function.
5. For forward operation, push lever switch (No. 6) to top position.
6. Check if temporary plug or the remote control (No. 7) is assembled to the seamer.

### **Important**

One of these plugs must be mounted to the seamer, always, otherwise machine will not run.

7. For double lock seam, check if all forming stations are placed correctly.
8. Insert Seamer K9-1 into the panel up to the first forming station.
9. Push start push button (No. 2) and seamer will be in operation.
10. If machine is not running, check fuse (No. 4).
11. For pictures and numbers see page 20 electronic switch box.

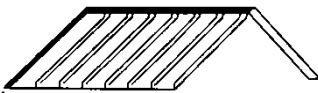

## Instructions how to work with the DUAL - Safety Switch K9-1 DF

1. Check if machine is equipped with a DUAL-Safety Switch K9-1 KF.
2. Plug must be inserted to the socket (No. 3) see label, K9-DF, electronic switch box.
3. Bottom seam switch, push to the top and insert pin into hole (No.8). This activates the seamer.
4. Push red switch to on (No. 1) light burns.
5. Choose forward, reverse or stop function with switch (No. 6). For forward operation, push lever switch to the top.
6. Push seam switch to the top and insert pin into hole (No. 9) to activate the machine.
7. Push start up button (No. 2), all forming stations must turn.

### ATTENTION

When working with the dual safety switch, the pin must be disconnected; otherwise seamer will not stop at the end of the seam. Check spring tension of seam lever switch at all times. Danger machine can fall off the roof.

8. Therefore insert the pin to hole (No. 9) for non-operation.
9. Set seamer and seam switch on top of the seam.
10. Push start up button (No. 2).
11. With the variable speed knob (No. 5) it is possible to increase the seaming speed from 5,5 m/min up to 13 m/min.
12. At the end of the ridge, eave or any other obstructions the machine shuts off automatically.
13. Seam switch below, shuts off at the end of the ridge, the front switch at any other obstructions.

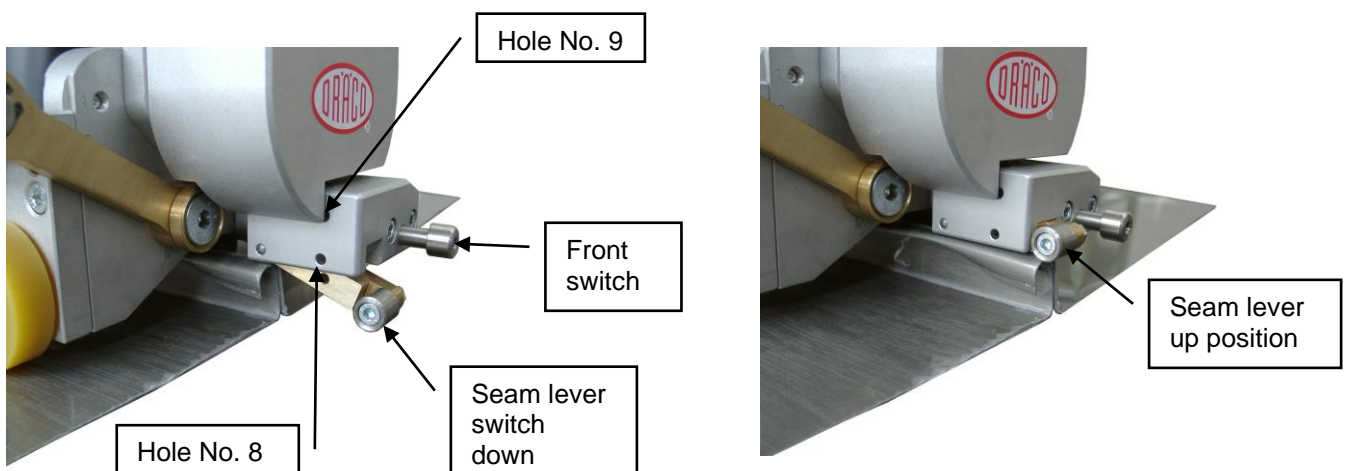

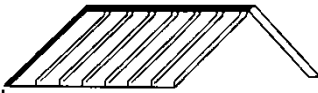

## **MAINTENANCE AND SERVICE**

No maintenance on the seamer is required.  
If machine is dirty, use a dry rag for cleaning.

Avoid storage outdoors for a long period.

Cover machine with a tarp for outside weather.

Keep your machine clean. This will increase the life of the machine and make maintenance easier.  
A clean machine will provide a clean product.

Repairs or maintenance of the seamer should be carried out only, by the manufacturer or an authorized dealer or qualified person.

Use original spare parts only.

## **WARNING**

Prior to use of this equipment, all operators must read the instructions carefully and educate themselves to the proper operation of this power seamer K9-1.

This equipment has some electric and moving parts, which could create potential injury.

The operator assumes all responsibility and liability for bodily or property damage in the operation or use of this equipment.

Dräco disclaims any responsibility or liability for injury or death caused by negligent operation or intentional misuse of this product.

## **IMPORTANT**

Please always read this manual before attempting to operate this machine and observe all safety signs.

# WARRANTY

## **12 MONTH WARRENTY ON PARTS ONLY**

**We warrant to the original purchaser that all DRÄCO manufactured parts shall be free from defects in material and workmanship for a period of 12 month from the date of shipment to the original purchaser. DRÄCO shall only be liable under this warranty if the product is used in a proper manner under normal use.**

In the event of a claim under this warranty the original purchaser shall provide written notice of the nature of the defect to DRÄCO, Gutenbergstr. 15-17, D 73779 Deizisau, Germany, may elect, at its option, to either repair or replace any DRÄCO manufactured parts proven to be defective on material or workmanship. Defective DRÄCO manufactured parts must be returned to the factory for warranty service, freight prepaid. Repaired or replacement parts will be shipped to the purchaser freight collect. DRÄCO'S warranty is limited to repair or replacement of defective parts received (freight prepaid) at the factory and does not extend to providing field service, machine adjustments, field repairs, freight, air- fare, direct or consequential costs, or expenses resulting from an associated with machine failure.

This warranty is VOID if the part or any machinery in which any parts are contained is altered, abused, misused, or neglected, or if required maintenance is not timely performed. Any failure of purchaser to properly install or use the product shall operate as a waiver of the breach of warranty, absolving Dräco Germany of any liability whatsoever. This warranty is further VOID unless the warranty registration card has been properly completed and returned, to DRÄCO Germany within thirty (30) days from the date of shipment.

Dräco gives notice that any statement made by the manufacturer in the sale of the product shall not create any warranty that the product shall be fit for any particular purpose. Statements or description are informational only, and purchaser shall be solely responsible for determining the adequacy of the product by purchaser, shall not be subject to any implied warranty or fitness for that or any other purpose.

**ALL OTHER WARRANTIES, EXPRESS OR IMPLIED, ARE EXCLUDED.**

Model No. \_\_\_\_\_ Machine Serial No. \_\_\_\_\_

THIS WARRANTY SHOULD BE RETAINED BY THE CUSTOMER FOR FUTURE REFERENCES.





# EG-Konformitäts-Erklärung Declaration of conformity

Im Sinne der EG-Richtlinie Maschinen 06/42/EG

**Max Draenert Apparatebau GmbH & Co.KG**  
Gutenbergstr. 15 - 17  
73779 Deizisau

**Fabrikat:**

Dachfalzschließer

**Artikelbezeichnung:**

**K9-1, K9-1-WAD**

Hiermit erklärt der Unterzeichner in alleiniger Verantwortlichkeit, daß die angegebenen Produkte mit den folgenden Richtlinien und Normen übereinstimmt.

We declare under our sole responsibility that this product is in conformity with the following standards or standardisation documents:

EG 06/42

DIN EN ISO 12100-1  
DIN EN ISO 12100-2  
DIN EN ISO 14121-1  
DIN EN ISO 13849-1

Made in Germany

Deizisau, 26.04.2010

Ort, Datum

Unterschrift / Inhaber

**Max Draenert Apparatebau GmbH & Co.KG - Elektro-Druckluftwerkzeuge** Germany

|                 |                     |   |                      |  |
|-----------------|---------------------|---|----------------------|--|
| <b>Werk I :</b> | <b>Verwaltung</b>   | D - 73777 Deizisau  | Postfach 1120        | Fax 07153-21468  |
|                 | Gutenbergstr. 15-17 | D - 73779 Deizisau  | Telefon 07153-8217-0 | Fax 07153-8217-66  |
| <b>Werk II:</b> | Seewiesenweg 1      | D - 73779 Deizisau  |                      |  |
|                 | INTERNET            | <a href="http://www.dracotools.com">http://www.dracotools.com</a> | E-mail:              | <a href="mailto:draenert@dracotools.com">draenert@dracotools.com</a> |